



48" AZ – EL MOUNT INSTALLATION INSTRUCTIONS

Congratulations! You have now purchased the finest AZ-EL mount available. This unit has been designed to give you the most stable system to work on a single pole application. Assemble using these instructions. If you have any questions please call 800-627-9443 for help.

The AZ-EL Mount is designed to go with the 3.0m, 3.7m & 3.8 meter antennas. As all are identical in theory, we will cover the basic installation first and address each individually as the installation requires. **PLEASE READ COMPLETE INSTRUCTIONS BEFORE BEGINNING INSTALLATION!**

If you will be storing the antenna for a period of time, a one piece antenna is to be laid flat on a level surface. Always store the antenna on its outer lip. **Shipping Warranty for missing parts is detailed on the last page of the manual.** A detailed parts list is provided on the page prior to the "shipping warranty". **Please refer to this section immediately on delivery.**



PARTS LIST

- 1 - DH Antenna
- 1 - AZ-EL Mount 48" Back Ring
- 1 – 5 1/2" I.D. Base Can
- 8 - Back Braces for 3.0m and larger
- 4 - Feed Struts
- 1 - Feed Collar
- 1 - Elevation Tube
- 1 - Elevation Tube Bracket
- 1 - Bolt Bag to include all Hardware
(see page 13)

***Galvanized back braces please immediately read special note on bolt bag page 13.**

DH Satellite

P.O. Box 239
Prairie du Chien, WI 53821
Phone: (608) 326-8406
Fax: (608) 326-4233
8 a.m. to 5 p.m. C.S.T.

Sectional antennas must be handled with care not to twist or distort sections while handling for installation.

AZ-EL MOUNT

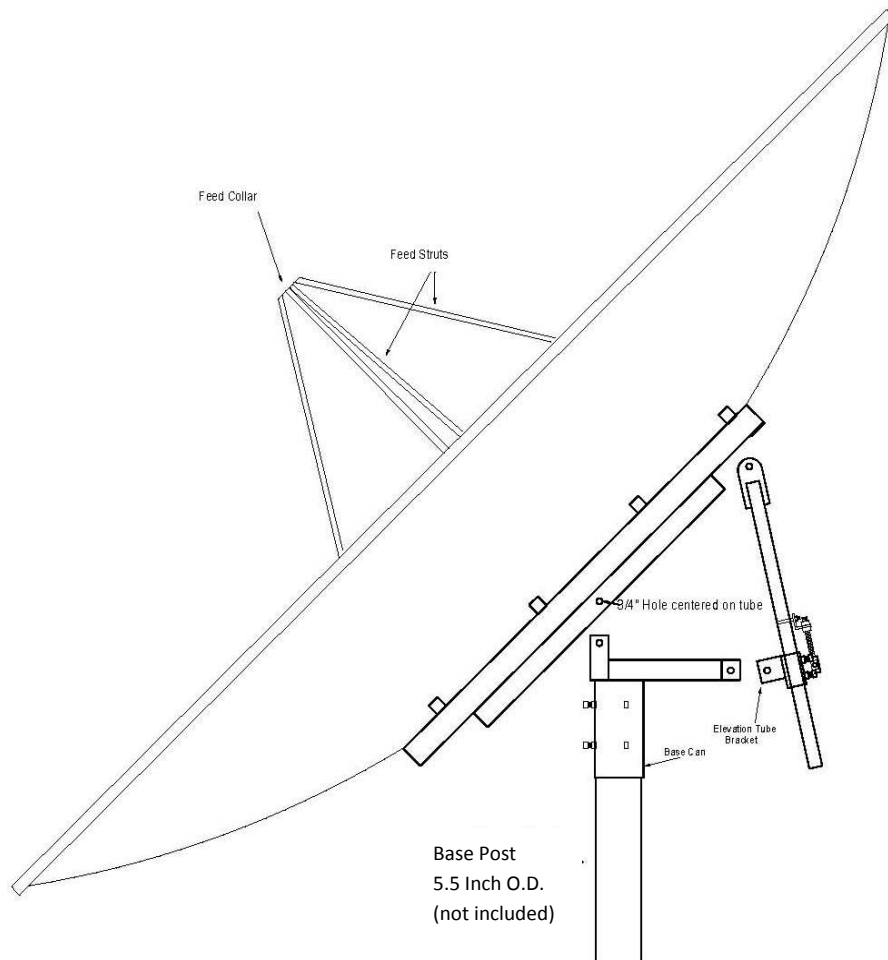

Installation of Base Post

Look at the drawings below, the first drawing shows the recommended concrete base. In areas of deep frost, we recommend that the base go below frost levels. 1/2" rebar can be used to reinforce the structure, if required; contact a local concrete contractor or a local Engineer to give you an idea of how much steel to use. **WE RECOMMEND THAT YOU CHECK WITH A LOCAL ENGINEER TO DETERMINE SOIL TYPE AND BEARING TO VERIFY THAT THIS BASE WILL WORK FOR YOUR LOCALE.**

With this AZ-EL mount, you have a choice of two different base assemblies. The first is a base post (see FIGURE #1). The base post is simply a 5" I.D. / 5 1/2" O.D. pipe that has one or more weldments on the lower section. We recommend that the post be in concrete at least 4'-0". When the post is set in concrete, be sure it is plumb. The second option is using either a square foundation or a sono tube shown in figure #2.

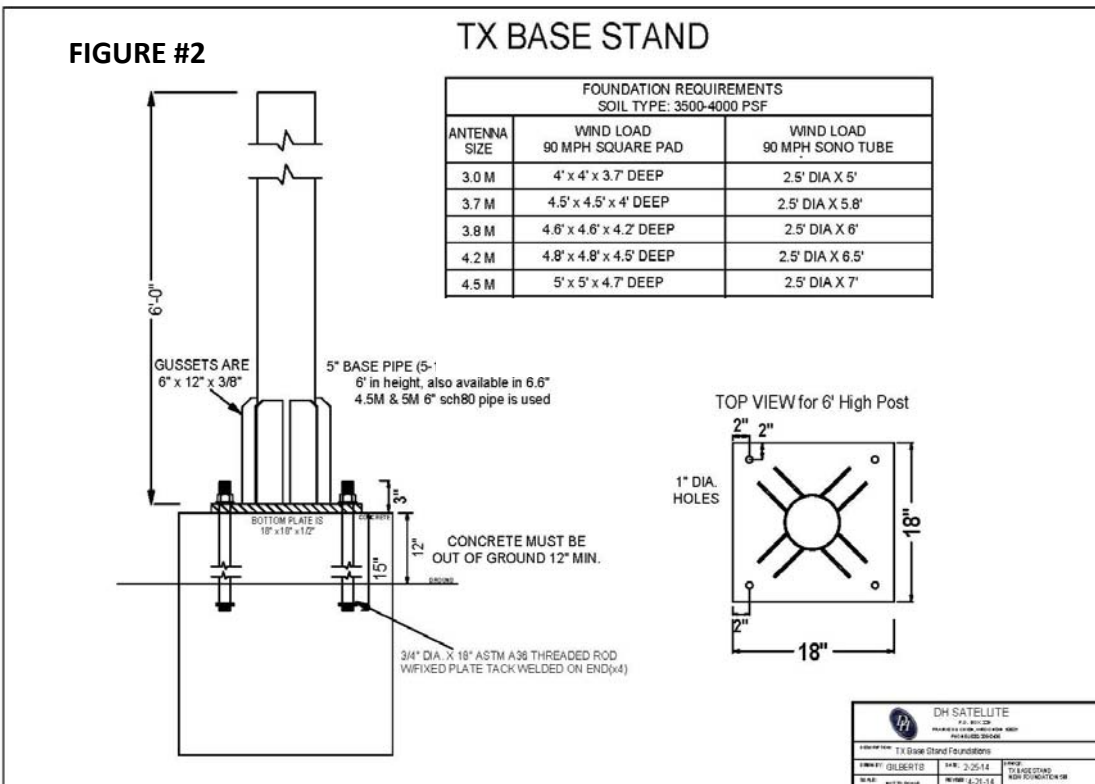
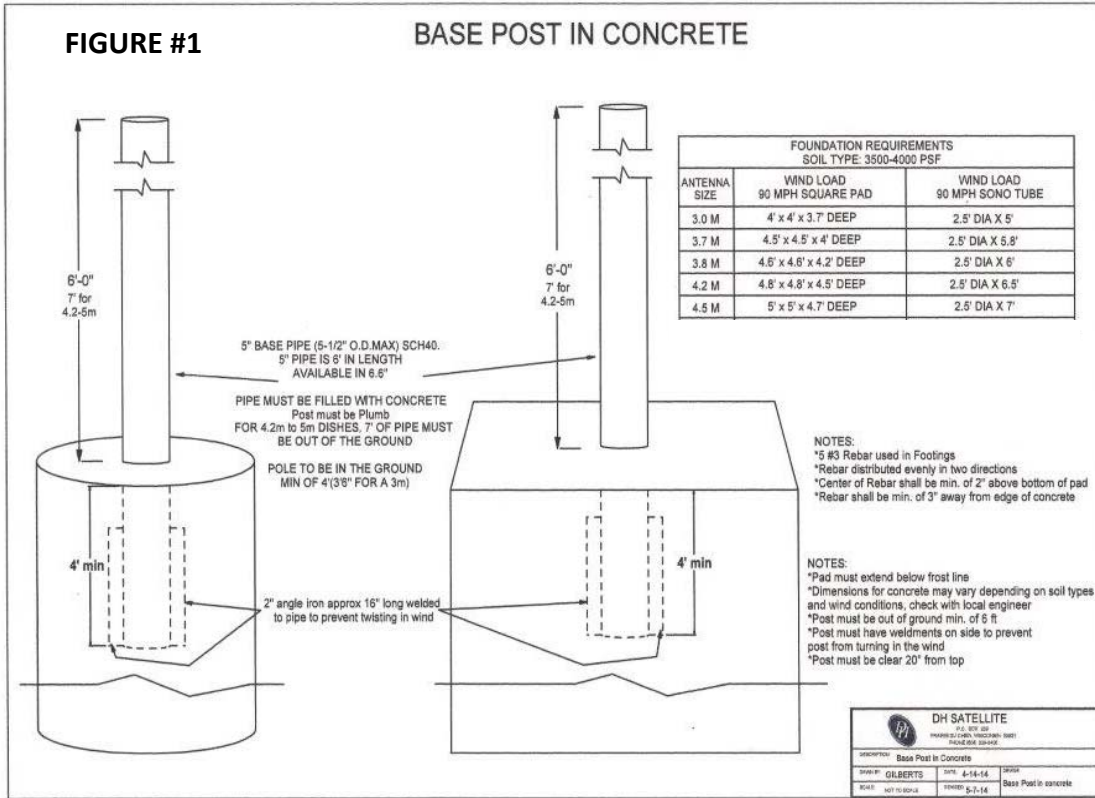

Installation of Base for the Four Leg Base Stand (continued)

Four Leg Base Stand
Discontinued as of June 1st, 2013

The second base assembly is our Four Leg Base Stand (Figure #3). This unit is designed to go above ground on a concrete pad. You can install this either of two ways; number one, you can request a template of the base stand and install J-bolts in the concrete as you are pouring it, or you can wait until you receive the base stand (having previously poured the pad) and drill the holes into the concrete using the stand as a template. You must use a type of lead head or garonite (a parafast resin mortar) to secure the bolts.

** Most local concrete companies stock this type of product.

*** If not available locally, DH Satellite can furnish the garonite.

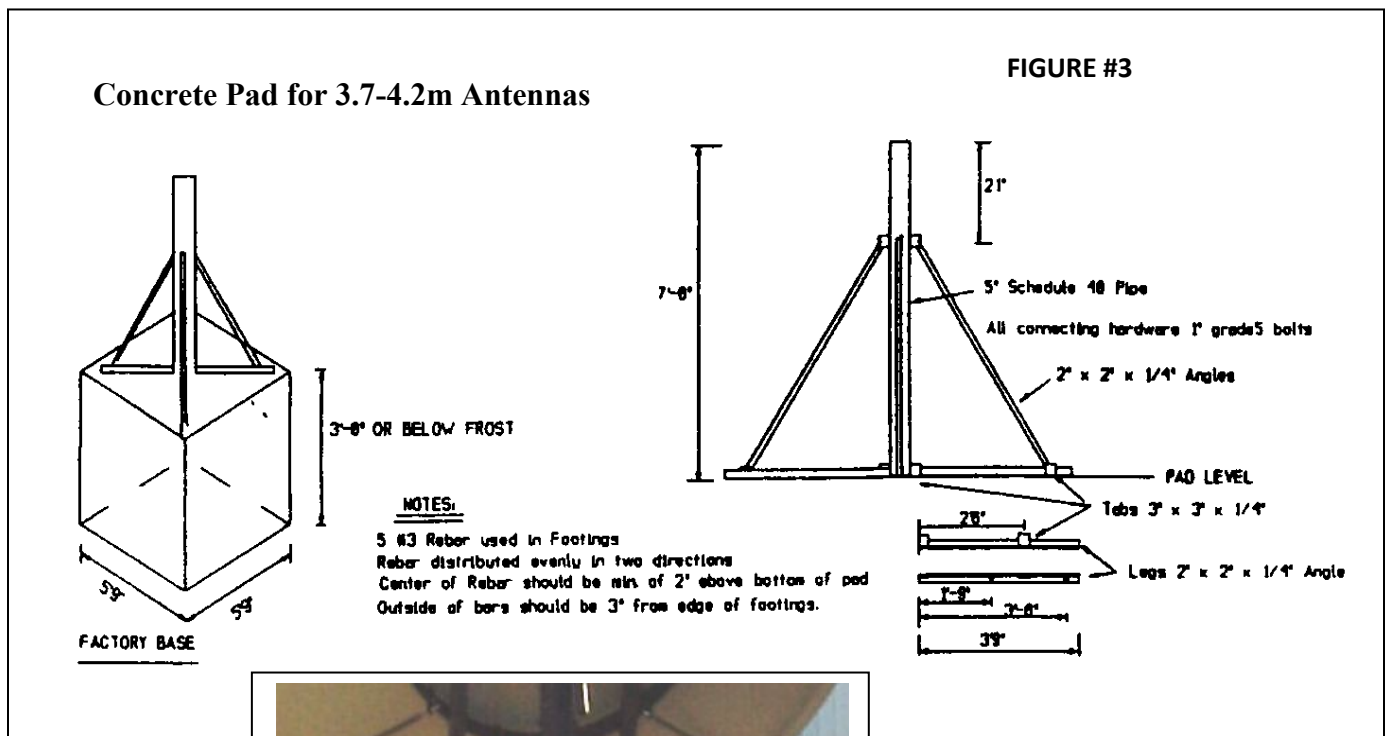

Garonite™ is a specially formulated, finley ground hydraulic cement. It expands while setting and will not loosen, shrink or crack under stress, vibration, heat or cold and will cure to strengths far exceeding those of regular concrete.

Garonite™ does not contain metallic fillings, calcium chloride or other corrosive agents. Garonite™ is supplied in ready-to-use form. Simply add water for special application when a high-strength, non-shrink, pourable consistency grout material is required, such as grouting heavy duty equipment when core drilling anchor bolts and base plates.

www.garonproducts.com

Assembling the Ring to the Base-----

Assembling the AZ-EL Mount is very easy (familiarize yourself with Figure #4), as there are only four parts to put together. First take the base can and set it on the base post. Tighten it with the 3/4" set screws. Take the 48" ring and place each of the two ears inside of the tubes and line up the holes on the ears with the holes in the tubes. You will notice the 3/4" holes in the center on each of the 2-1/2" x 2-1/2" tubes welded to the 48" ring. Place the 3/4" x 4-1/2" bolts through the holes and secure with the lock washers and nuts provided.

Place the elevation tube bracket onto the elevation tube. Tighten the set screws to hold it in place. Take the top end of the elevation tube, the end with the 2-1/4" x 5" plate welded on and place it in the brackets on the cross member of the ring. You will use a 3/4" x 2-1/2" bolt, lock washer and nut. Go to the elevation tube bracket and place the tab with the 3/4" hole into the tab brackets at the back of the base can. Secure it with a 3/4" x 2-1/2" bolt, lock washer and nut. Make sure the bolts are secure, but leave them slightly loose until you have aligned the antenna on the satellite you will be using. Once you have aligned the antenna, tighten all bolts and nuts.

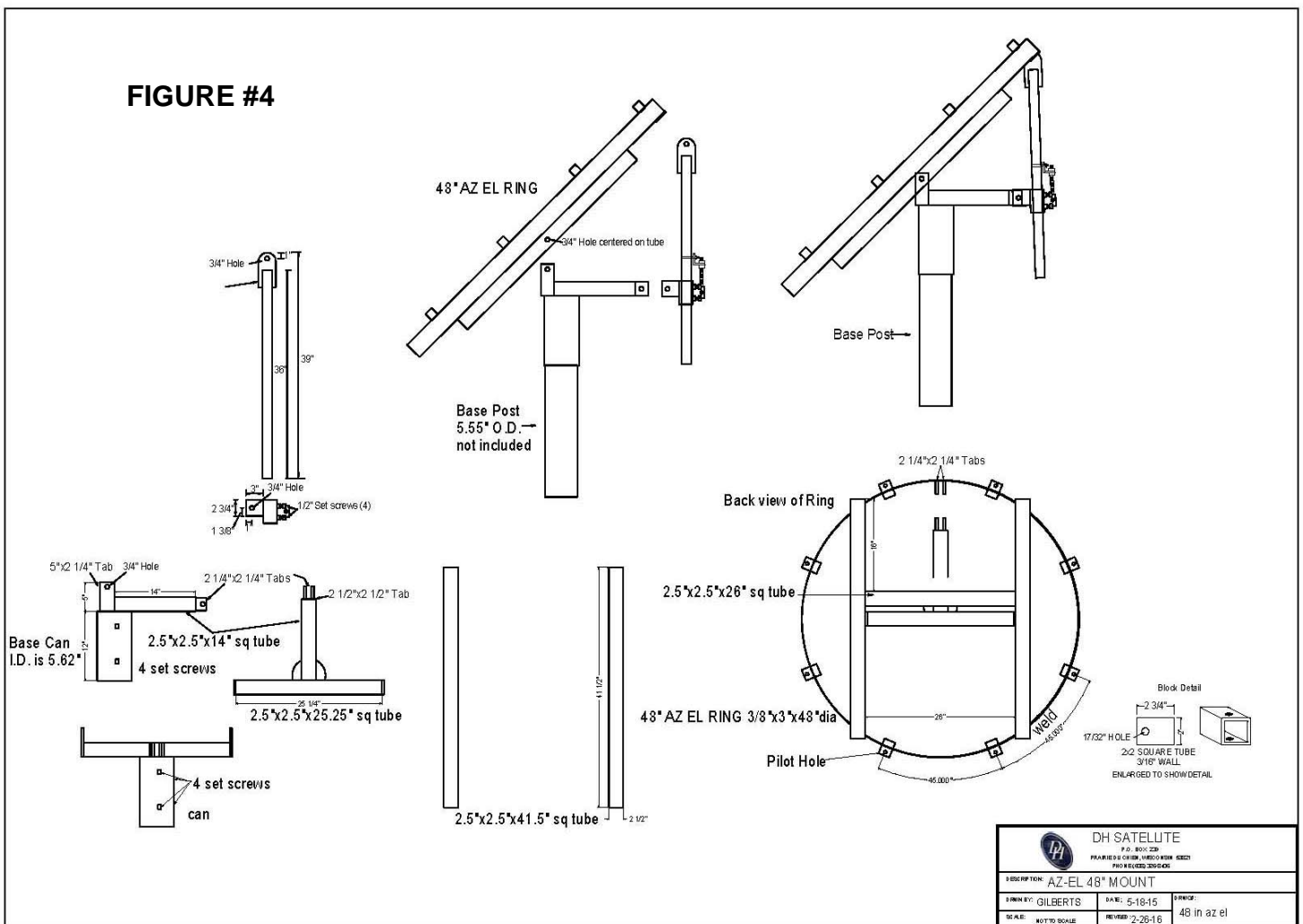

IMPORTANT!!

If you have purchased a 4 or 8 piece sectional antenna follow the instructions on page 5 and 6.

ASSEMBLY OF THE ANTENNA

(On Ground: Lift As One Piece Antenna)

The antenna will come in 4 or 8 pieces each having a color coded dot on the rib (see **FIGURE #5**). **NOTE: After complete installation you will no longer see the colored dots.** You must take two sections of the antenna and place them on a flat surface face down allowing for the installer to work on attaching the numbered ribs. The antenna must always stay in crate until assembled. (see **FIGURE #6**) Take panel one labeled 08/1 and 08/2 and attach it to panel 2 which is labeled 08/2 on one rib and 08/3 on the other rib. Connect panel 1 with rib #2 (labeled 08/2) to panel 2 with rib #2 (labeled 08/2), matching the #2 on each rib of the two panels (See photos below). Install 1/4" x 3/4" bolts in all holes, finger tight. Continue on to the next panel in the same manner until finished with all panels. Now tighten all hardware.

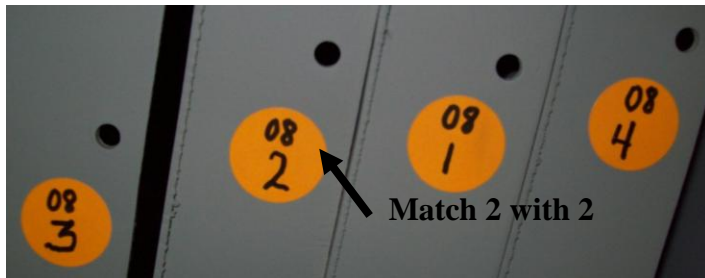

FIGURE #5



FIGURE #6

NOTE:

The aluminum antenna is also stamped in the lip. This number reflects the position of the panel.

The number stamped on the rib reflects the antenna as a whole for bulk shipping. Each section has one rib stamped. The number will be the same on all ribs making it one complete antenna.



RIB

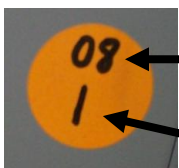

The top number represents the serial number of the antenna. ***Example:** In FIGURE #5 you will see 4 sections with the top number 08. You will take all four pieces of 08 to make one complete antenna.

The bottom number represents the rib number. ***Example:** On a 4 piece 3.0m antenna the dot will have a 08 on the upper part of the dot (serial number) and the lower number of 1, 2, 3, or 4 (rib numbers).

See optional sectional installation on page 6: "Installing by Sections to Ring"

“OPTIONAL ASSEMBLY METHOD”

(Install By Sections: Using 2-3 People)

Assemble mount , using the elevation tube to place mount in birdbath position. Be sure to tighten the elevation tube and lock the mount with ratchet straps once in **birdbath position**. (See **PHOTO D**)

Step 1: Install the brace clips to all 8 back braces, using a 3/8” x 2” bolt, 3/8” nut and a 3/8” lock washer. Initially, only tighten these ‘finger tight’. Next, install a 1/2” nut at the end of the back brace, threading it down approximately 4 to 4 1/2” down the threaded rod. (See **FIGURE #7**)

Step 2: Install the bent tabs to the 48” Ring. The bent tabs are a piece of steel bent in the middle, approximately 1 1/2” x 3” long with two holes (you will find these in the bolt bag). Fasten the bent tabs with 1/2” bolts, and a 1/2” nut. (See **FIGURE #8**)

Step 3: Take the first panel(the panel that has the pilot hole) and install it to the ring of the mount finger tight. Be sure to start with the pilot hole on the mount and on the antenna. Take the back brace that is ready and put the threaded rod through the tab on the ring (see **PHOTOS A & B**). Take the other end of the rod with the clip and attach the brace and clip to the lip of the antenna section (see **PHOTO C**).

Step 4: Insert 1/2” x 3” bolt (see **FIGURE #10**) for washers and rubber placement) from the antenna to the mount. Have one person continue holding the panel in place while the second person attaches the back brace. (Remember the threaded end of the back brace should already have the 1/2” nut on the threaded end about 4-4 1/2” on the threaded rod and the bent tab already installed on the ring, (see **FIGURE #8**). Insert the threaded rod of the back brace into the bent tab and bolt brace clip on the edge of the antenna with 1/4” x 3/4” bolt, 1/4” nut and 1/4” lock washer. Make sure everything is only ‘finger tight’.

Step 5: Pick up the second antenna panel and be sure the numbers line up(so “2” mates up to “2”, “3 to “, etc. and bolt in place just like the first panel. (see **FIGURE #9**) Once secure you can begin bolting the two units together by placing the 3/8” x 1” bolts and washer through the templates. Secure with washer, lock washer and nut and only ‘finger tight’. Continue for the remaining panels. Once all sections have been installed, securely tighten all of the hardware.

STEP 6: Once the antenna is secured to the ring, install the feed assembly to the antenna. Use the 4 outer mounting holes beyond the 8 bolts that fasten the antenna to the ring. It is best to assemble the feed assembly on the ground and then lift it up to place.

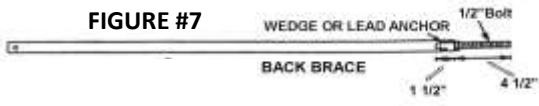

PHOTO A

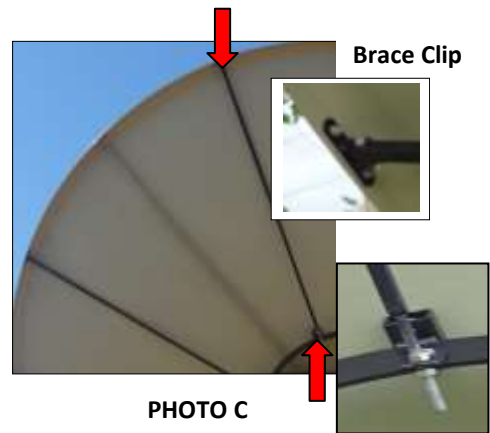
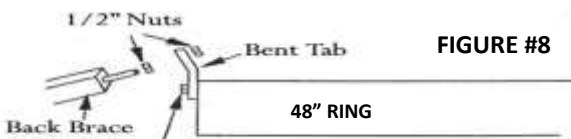

PHOTO C



1/2” x 1 1/2” Bolt

Back braces are measured by tube length only.



PHOTO B

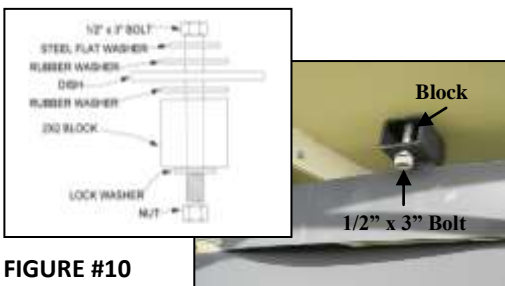

FIGURE #10



PHOTO D

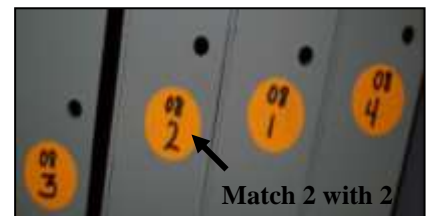

FIGURE #9

ASSEMBLING THE ANTENNA TO THE RING

This section/page is for assembly of a 1pc solid antenna or a sectional antenna assembled to install as a 1pc antenna.

(3M-4.5M)

The mount should be assembled and now it is time to install the antenna. We recommend two methods of lifting the antenna onto the post.

The first option is using the Ground method.

Place the antenna face down and with a person under the antenna, you will place the ring on the antenna. Put the bolt from under side up through the dish and ring tabs. Attach the 8 back braces, clips, and tabs on the ring and tighten, but not too tight as we need to allow for flex. You can now lift this antenna and ring by a crane, forklift or a boom truck. This insures that no pressure will be put on the antenna.

The second option is the Bird Bath method.

If you are going to use manpower, follow these instructions. First you must elevate the ring to about 60 degrees. Lock it in place. Now locate the 1/8" pilot holes on the ring and the antenna. One is located next to one of the eight 1/2" holes in the dish and the other is located on one of the 8 blocks next to 1/2" holes on the mount. (**See FIGURE #11**) (These pilot holes are only to locate the two 1/2" holes they will not line up from the mount to the dish.) When you have located these two holes, use 4 -5 people and pick up the dish and set it into the ring making sure the pilot holes line up. **BE EXTREMELY CAREFUL IN HANDLING THE ANTENNA WHEN SETTING IT INTO THE MOUNT.** Now slip in the 1/2" x 3" bolts, (leave out every other bolt when using a C, Ku, C/Ku, or S – band feed.) Do not tighten these bolts more than just snug. Now put the dish in a very flat position (birdbath). Have the smallest worker (installer) get into the dish and install the feed and hold the bolts while they are tightened. Install the bolts as in **FIGURE #12. DO NOT OVER TIGHTEN.**

FIGURE #11

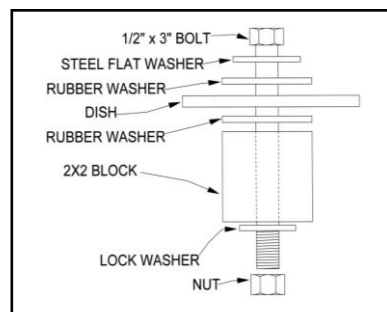
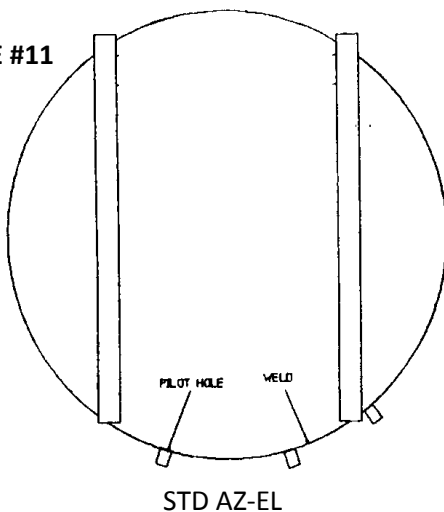
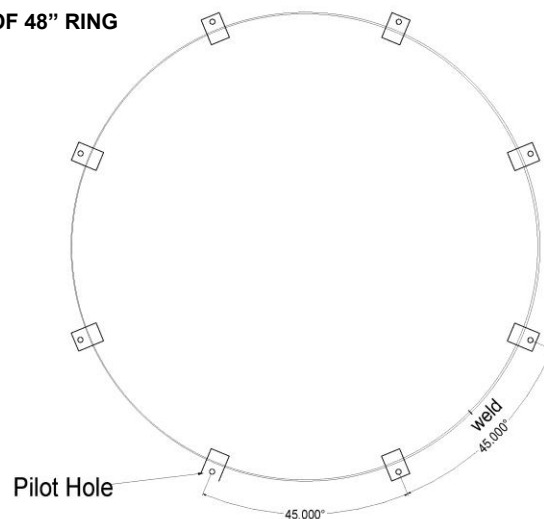

FIGURE #12

BACK VIEW OF 48" RING



Note:

ON A ONE PIECE ANTENNA, THE WELD OF THE ANTENNA IS ALWAYS LINED UP WITH THE BOOM OF THE MOUNT

*FROM THE BACK VIEW OF ANTENNA

Pilot hole is located on the 2nd block from the left of the weld on the ring.

Assembling & Installing the Back Brace----

There are eight holes around the rear of the 48" ring to accept the braces. First install the bent tabs. (See **FIGURES #14 & #15**) The bent tabs are a piece of steel bent in the middle, approximately 1 1/2" x 3" long with two holes; you will find these in the bolt bag. Fasten the bent tabs with 1/2" bolts to the 48" ring; thread one 1/2" nut about 2/3 of the way down on the 1/2" rod end of the brace. Slip the rod end thru the tab and install another 1/2" nut. Only tighten these finger tight. Go to the edge of the dish and place the two 1/4" x 3/4" bolts thru the dish and into the end of the brace clip and tighten with 1/4" nuts. Fasten the end of the back brace to the brace clip using 3/8" x 1 1/2" bolt and 3/8" locknut. (Refer to Figure #5 on pg. 6) Repeat this on all eight braces on the 3.0m, 3.7m, 3.8m, 4.2m, and 4.5m antenna.

Set the dish in its position for the desired satellite and walk 30 feet away and sight the front surface of the dish. It should be flat. If it is not, adjust any braces that may be holding pressure and try to make the front surface flat. Try to do very little adjusting and try to release pressure to make flat. Stringing the antenna in four locations is advised. String from back braces parallel to each other across the face of the antenna, making certain the strings are taut. Adjust so that the strings just touch in the center. (See **Page 9** for antenna fine tuning.)

The following is a list of the different back braces for the different size antennas. Check this chart to be sure you have the right length braces. Listed is tube length only and does not include the bracket or the bolt in this measurement. (Refer to **FIGURE #13**)

Dish Size	Focal Length	Tube Length
10' (3.0m)	36" f/l	37"
12' (3.7m)	57.6" f/l	50"
12'5" (3.8m)	57.6" f/l	53"
14' (4.2m)	57.6" f/l	62 1/2"
14'9" (4.5M)	57.6" f/l	68 1/2"

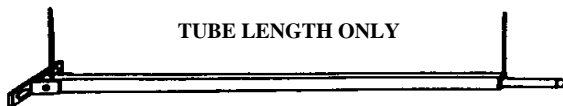

FIGURE #13

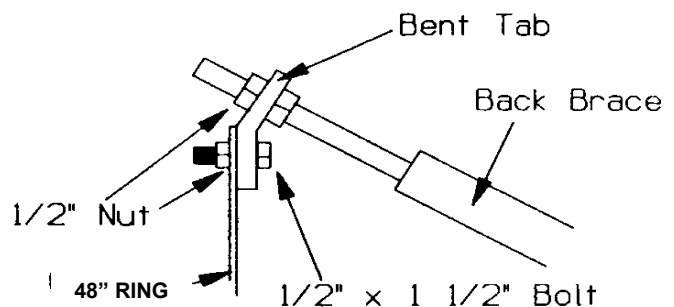

FIGURE #14

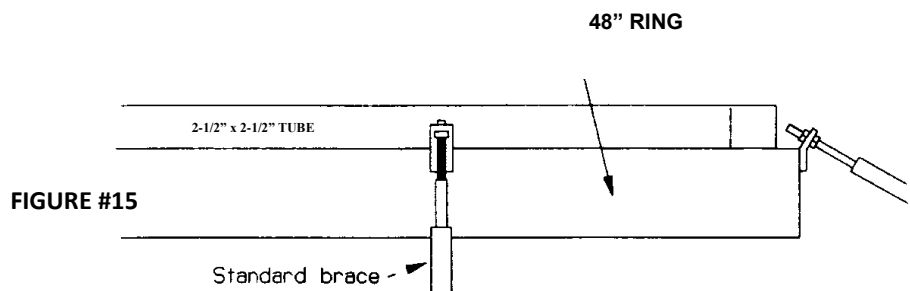

FIGURE #15

Fine Tuning the Antenna-----

To get the most gain from your antenna, take an extra hour to make the adjustments needed and if possible use a Spectrum Analyzer. You will be able to see your increase or decrease gain with each adjustment you make. To begin, string the antenna. You do this by simply taking a string and tying it to one brace and running the string across the front of the antenna to the other brace at 180 degrees, tying it so it is taut. Tie another string to a brace 90 degrees from the first brace and run it to the corresponding brace 180 degrees away. Be sure you put the string on top or under the other string so they do not touch each other. You should, when done, have four strings at 90 degrees and they should meet in the center of the antenna. If the strings don't touch at the center, then you will have to do some adjusting with the braces. BE SURE YOUR STRINGS ARE TAUT. Stand back about 30 feet and sight the antenna to see where you must apply pressure with the braces or relieve the pressure from another area. Go ahead and make small adjustments with the braces, each time checking with the Spectrum Analyzer to see that you are increasing the gain of the antenna.

Elevation Fine Tuning-----

The fine tune adjustment for the elevation of the AZ-EL Mount is very simple to operate. First elevate the antenna to the satellite and lock the elevation rod down. Tighten the U-bolt on the tube and loosen the bolts on the bracket that hold the tube. The tube now can be moved up and down by loosening and tightening the nuts on either side of the bracket. You can make very small adjustments with this bracket, thus optimizing your signal.

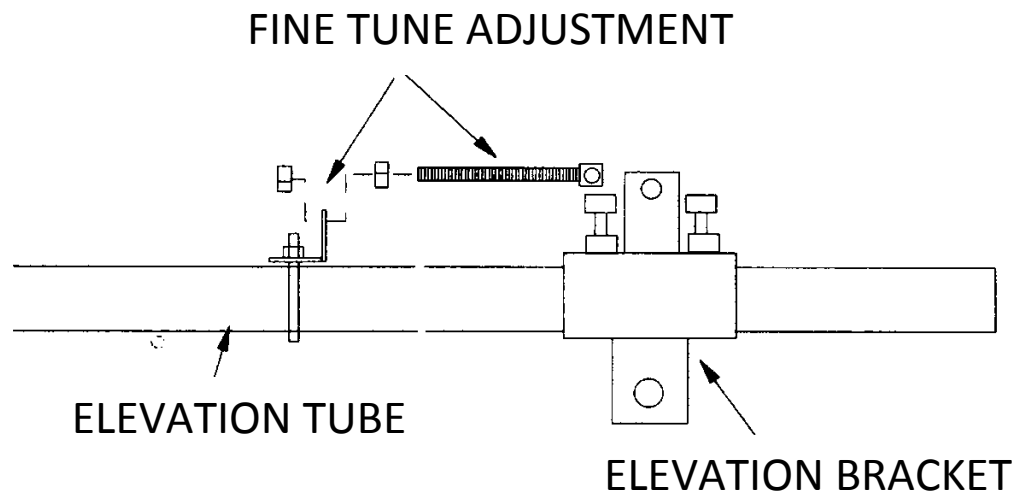

ELEVATION TUBE ASSEMBLY

Preparing the C Band Feed Assembly C14F2018

If the feedhorn you have selected has an adjustable scalar ring, move it to the proper wave guide setting as per the manufacturer's instructions. Below we have listed the focal lengths and focal length diameter ratios for our commercial antennas. Just find your antenna and you will have the information to set the scalar properly. **Special Note: More critical than setting the wave guide to the manufacturer's recommendations is to make sure you are setting the feedhorn at the correct focal length of the antenna.**

Antenna Size	Focal Length	Focal Distance
10' (3.0m)	36" f/l	.3 f/d
12' (3.7m)	57.6" f/l	.4 f/d
12'5" (3.8m)	57.6" f/l	.378 f/d

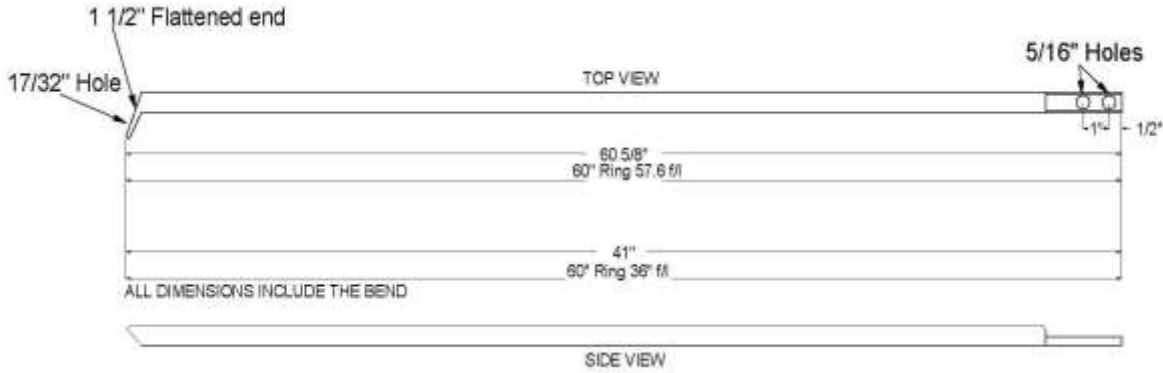

NOTE: C14F2018 Strut length includes bend in measurement.

Your DH representative should have asked you what type feed you will be using. We need this information to be assured we are sending the proper collar to attach your feed to our struts. A DH C14F2018 is supplied as standard unless you have made a request for another style collar. Place the C14F2018 collar or collar supplied on the back of the feedhorn scalar ring. Turn the scalar plate off the feedhorn so that all three holes line up between the slotted holes on the feed collar. Insert the 1/4" x 3/4" bolts through the scalar ring and then thru the collar; fasten with the 1/4" nuts. (Most C-band and dual feeds have a 3-bolt pattern on the scalar ring as described above).

For heavy duty SEAVEY (C24HD) or heavy duty CHAPARRAL (C14FHD) feed assembly please refer to page 10 and page 11.

For CHAPARRAL type feeds, refer to Figure #10. Slip the feed strut into a tab on the collar and line up the two holes. Insert the 2 – 5/16" x 3/4" bolts into the holes and tighten with the 5/16" nuts. Proceed with placing all four struts in every other hole, then check and measure the focal length according to instructions and tighten down. Be sure your focal length is set correctly and you're looking at the center of the dish. On a Chaparral style feed the actual focal length should be 1/4" inside the waveguide for C-band and 1/8" for Ku band. Seavey recommends the focal length is measured to front of the scalar ring.

***The Feed Struts will attach to the antenna through the 4 holes that are beyond the 8 bolts used to hold the antenna to the ring. (see photo to the right*)**



C14F2018

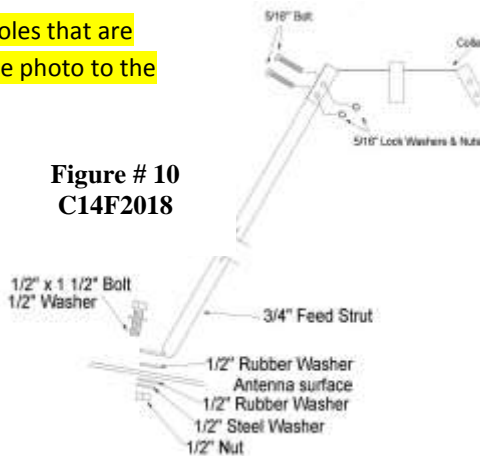

**Figure # 10
C14F2018**

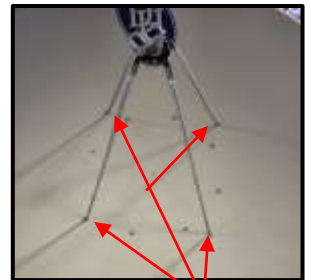

***Feed strut holes beyond mounting holes of antenna**

For use of Chaparral Feeds C14F2018

Heavy Duty Feed Strut_____

We have developed a new feed strut and collar for the heavier 4 Port Seavey and Chaparral feed assemblies. This utilizes the rectangular aluminum tube for the feed strut. **Refer to the drawing on Page 12 for the bolt placement of a C14FHD or C24HD.** Each strut has 2 - 5/16" x 2 1/4" bolts to attach to the feed collar. Attach one of the angle brackets (2" x 2") to the antenna with the 1/2" x 3" bolts. Notice that angle brackets have two holes. The bottom hole is for a Seavey type feed (C24HD). The top hole is for a Chaparral type feed (C14FHD). Next, attach the base of the strut to the angle brackets with the 5/16 x 1 1/2" bolts supplied. Align the feed to point directly at the center of the antenna. Measure the focal length to the front of the scalar rings. **(Seavey recommends f/l is measured to front of scalar ring.) (Chaparral measures 1/4" inside the wave guide.)**

Ku Band Feed Assembly_____

When using the Ku only feeds, you will be using the C14F feed plate and tri-collar. (See **FIGURE #13**) First, **attach the flat tri-collar to the feedhorn as follows:** attach the first two pieces by using the 8-32 x 1" screws provided. Now slide the collar onto the feedhorn and add the third piece; tighten evenly. Attach the tri-collar to the larger horseshoe collar by the 8-32 x 3/4" bolts and nuts; tighten down. You can adjust polarity by loosening these nuts and rotating feed. Finish by assembling the struts to the feed collar as shown in **FIGURE #18.** (**FIGURE #18** shows single Ku feed inserted in collar.)

FIGURE #17

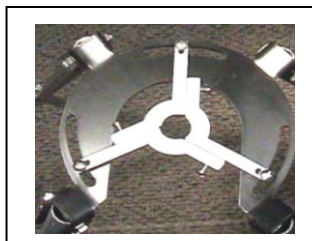
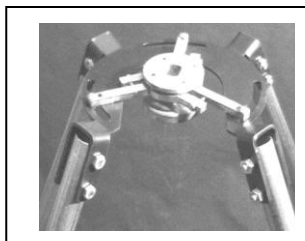

FIGURE #18



C14F-HD/C24HD 48" MOUNT

Notes

This strut is used for 48" mount with:
 HD Feed collar
 Black painted end goes toward the Antenna on 48" Mt
 Use the top 2 holes on the strut for the C14HD or C24HD
 Bolt goes through the 1-1/2" wide side of the feed strut

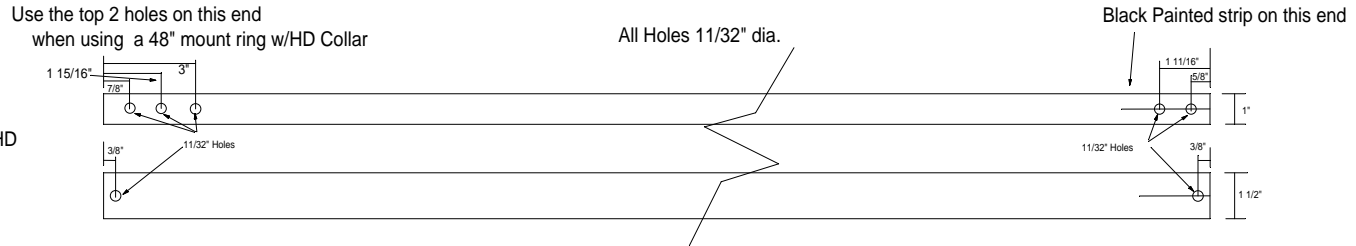

3.7m, 3.8m, 4.2m, 4.5m uses 58" x 1" x 1 1/2" Struts
 3 meter uses 37 5/8" x 1" x 1 1/2" Struts

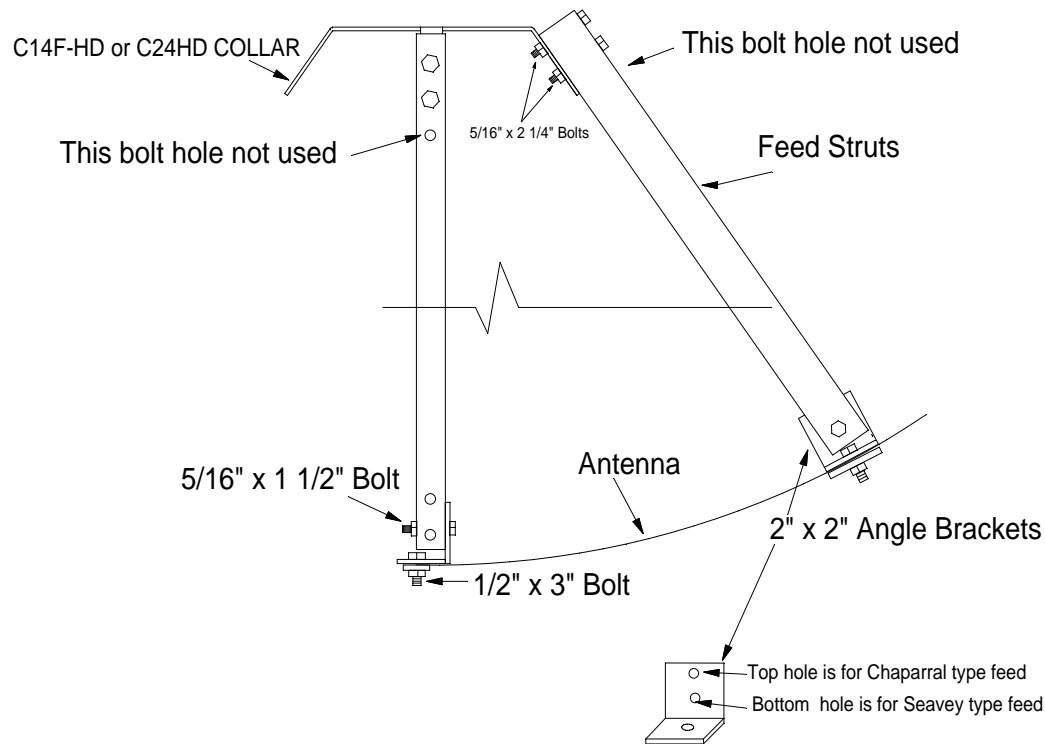

 DH SATELLITE P.O. BOX 239 PRAIRIE DU CHIEN, WISCONSIN 53821 PHONE (608) 326-8406		
DESCRIPTION: Feed Assembly for 48" Ring: C14F-HD/C24HD		
DRWN BY: MD/GILBERTS	DATE: 7-31-98	DRWGR:
SCALE: NOT TO SCALE	REVISED: 3-2-16	C14HD feed for 48ring

ADDITIONAL FINE TUNING TECHNIQUES

To receive the optimum from your antenna, you must take time to fine tune the antenna. What are the antenna adjustments? They are: make the front surface flat, be sure the feed looks at the center of the dish, and set the proper focal length. You must also be pointed at the satellite and have the feedhorn skew properly adjusted.

Many of the adjustments are done without any measurement of the signal, and in fact require no signal at all. The adjustment of making the front surface flat, adjusting the focal length, and aligning the feed will be done without signal. You will use the strings and the back braces to make the dish flat, a focal finder and measure tape to align the feedhorn to find center, and set the focal length using a measure tape to measure from dish to feedhorn. You will use a satellite tool to locate signal in further steps of fine tuning.

We feel that you must use strings to assure the front of the dish is flat. The strings must be taut and run from brace to the opposite brace at 180 degrees. A dish with 8 braces needs four strings. Do all adjustments with the braces loose. The strings must touch at the center, if they do not, sight the dish from the side to see which braces should be slightly adjusted to make the front surface of the antenna perfectly flat. **CAUTION: do not over tighten the 8 bolts that hold the dish to the ring as they can distort the dish.**

The easiest way to assure yourself that the feedhorn is looking directly at the center of the antenna is to use a Focal Finder (SEE PHOTO "A" BELOW) or to make a tool to assist in finding the center of the antenna. You can if no focal finder is available, cut a 1" X 4" board to the length of the antenna's focal length. Held vertically against the feed it should point at the center of the antenna, this will be true at the horizontal plane as well.

DH recommends using an AI Turbo S2 made by Applied Instruments or another tool such as a spectrum analyzer to locate your satellite signal in order to complete the following steps:

Setting the Azimuth: To set the azimuth of the system you will use the base can and a tool to locate and measure signal. Find a satellite signal using the AI Turbo S2 or another satellite tool that will show signal spiking. Any signal strength will work. This is your reference point. Now you will go from bad signal to bad signal. From this reference point you will move the antenna left of the reference point to see if the signal gets better or worse and right of the reference point to see if this makes it better or worse. When you see the location of the base can for the best signal, you will tighten down the set screws on the base can. **(Special Note: It is best to make a mark on the pole and base can to reference your starting point before making any moves with the base can. Re-mark your base can and pole so that you now know the location that is allowing the strongest satellite signal.)**

Setting the Elevation The fine tune adjustment for the elevation of the AZ-EL Mount is very simple to operate. First elevate the antenna to the satellite and lock the elevation rod down. Tighten the U-bolt on the tube and loosen the bolts on the bracket that hold the tube. The tube now can be moved up and down by loosening and tightening the nuts on either side of the bracket. You can make very small adjustments with this bracket, thus optimizing your signal.

Skewing the feedhorn: You will rotate the feedhorn; again going from left or right of the marked reference location for your feedhorn, to find your strongest signal. Once you find your strongest signal tighten down into place.

Keep in mind when you are making these last "Additional Fine Tuning Techniques" very small moves will be needed to make the best improvements in signal strength.

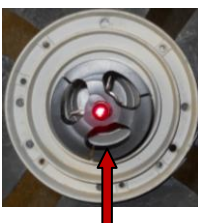
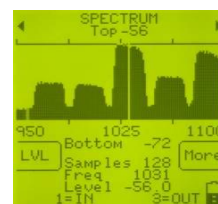
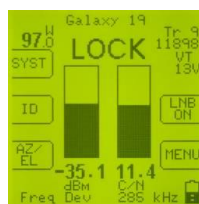

PHOTO A
Focal Finder to Locate
Center of Antenna



**AI Turbo S2 Made By Applied
Instruments**



BOLT BAG FOR: 48" AZ-EL MOUNT

C14F feed Assembly

- 1- Set of 4 Struts
- 1- Collar (C, Ku)
- 8- 1/4" x 1 1/2" Bolts
- 8- 1/4" Lock Washers & Nuts

***New Style Collar C14F2018 transition Starts April 16th, 2018**

*C14F2018

Feed Assembly

- 1- Set of 4 Struts
- 1- Collar (C, Ku)
- 8- 5/16" x 3/4" Bolts
- 8- 5/16" Lock Washers & Nuts

Base Can to Mount

- 2- 3/4" x 4-1/2" Bolts
- 2- 3/4" Nuts
- 2- 3/4" Flat Washers
- 2- 3/4" Lock Washers

Antenna to Ring (8 Block)

- 8- 1/2" x 3" Bolts
- 8- 1/2" Flat Washers
- 16- 1/2" Rubber Washers
- 8- 1/2" Lock Washers
- 8- 1/2" Nuts

Back Braces

- 8- Back Braces
- 8- Brace Clips
- 8- Bent Tabs
- 8- 1/2" x 1 1/2" Bolts
- 24- 1/2" Nuts
- 8- 1/2" Lock Washers
- 8- 3/8" x 2" Bolts
- 8- 3/8" Nuts
- 8- 3/8" Lock Washers
- 16- 1/4" x 3/4" Bolts
- 16- 1/4" Nuts
- 16- 1/4" Lock Washers

Highly Recommended On Systems With Galvanized Back Braces

Please use a rubberized spray or silicon sealant to coat the threaded rods on the end of back braces to help prevent corrosion. When doing annual maintenance on your antenna system please make sure to check as it may need to be reapplied.

NOTE: 3.0m, 3.7m and 3.8m antenna systems have 15/16" galvanized round tube back braces. 4.2m and 4.5m have square tube back braces.

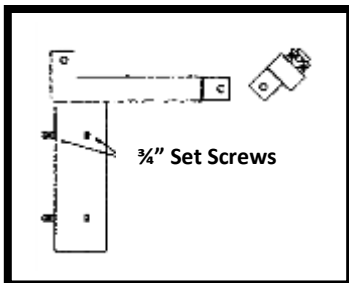

BASE CAN WITH SET SCREWS

Feedhorn to Collar & LNB

- 3-1/4" x 3/4" Bolts
- 3-1/4" Lock Washers
- 3-1/4" Nuts

(LNB to Feed)

- 20-1/4" x 3/4" Bolts
- 20-1/4" Nuts
- 20-1/4" Lock Washers

Elevation Assembly

- 1- Elevation Clamp
- 1- Elevation Tube (36" Long)
- 2- 3/4" x 2-1/2" Bolts
- 2- 3/4" Nuts
- 2- 3/4" Lock Washers

Fine Tuning Kit

- 1- 5/16" x 2 U-bolt
- 2- 5/16" Lock Washers & Nut
- 1- 3" x 2" x 2" Elev. Angle
- 1- 5/8" x 8" Eye Bolt
- 2- 5/8" Nuts
- 1- 1/2" x 1 1/2" Bolt
- 1-1/2" Nut
- 1- 1/2" Lock Washer

Back Brace Length

- 3.0m- 37" Long
- 3.7m- 50" Long
- 3.8m- 53" Long
- 4.2m- 62 1/2" Long
- 4.5m- 68 1/2" Long

Feed Struts to Antenna

- 4- 1/2"x1-1/2" Bolt
- 8- 1/2" Flat Washers
- 8- Rubber Washers
- 4- 1/2" Lock Washers
- 4- 1/2" Nuts

Ku4FL: 3PC

ADD TO C14F

- 3- Section to 3pc collar
- 3- 8-32 x 1" Bolts

3pc Collar to Horseshoe

- 3- 8-32 x 3/4" Bolts
- 3- #8 Fender Washers
- 3- 8-32 Nuts

Heavy Duty Feed Struts C14F or C24

- 1- Set of 4 Struts
- 1- Collar (C, Ku)
- 12 - 5/16" Lock Washers & Nuts
- 4- 2' x 2' Angle Brackets
- 4- 5/16" x 1 1/2" Bolts
- 8- 5/16" x 2 1/4" Bolts



NOTE: SECTIONAL ANTENNAS INCLUDE ADDITIONAL HARDWARE, SEE TABLES BELOW

Template Rib Hardware: Sectional			
Antenna Size	1/4" x 3/4" Bolts	1/4" Lock Washers	1/4" Nuts
3.0M	44	44	44
3.7M	52	52	52
3.8M	56	56	56
4.2M	120	120	120
4.5M	136	136	136

Splice Straps: Sectional				
Antenna Size	Splice Straps	1/4" x 3/4" Bolts	1/4" Lock Washers	1/4" Nuts
3.0M	4	8	8	8
3.7M	4	8	8	8
3.8M	4	8	8	8
4.2M	8	16	16	16
4.5M	8	16	16	16

If you have upgraded to an 8PC 3.7M sectional antenna please refer to the tables below for additional hardware needed.

Template Rib Hardware: Sectional			
Antenna Size	1/4" x 3/4" Bolts	1/4" Lock Washers	1/4" Nuts
3.7M	104	104	104

Splice Straps: Sectional				
Antenna Size	Splice Straps	1/4" x 3/4" Bolts	1/4" Lock Washers	1/4" Nuts
3.7M	8	16	16	16

NOTE:

Stainless Steel or DURA-CON® hardware provided.

*DURA-CON® is a corrosion resistant coating.

DURA-CON®: Problem of thread-galling is eliminated.

MISSING PARTS WARRANTY

You have obtained one of the best antennas on the market today!
We hope that you will be happy with your new DH Antenna.

To better acquaint you with our system, we ask that you read the instruction manual and verify that all of the equipment has been supplied in your shipment. Please check the hardware as well as the parts list and compare to what you have received. It is our policy to make every effort to assure you that you have received all parts necessary to make this a pleasant experience.

While checking over your parts it is possible to find that you are missing pieces that are necessary to complete the installation. You will find below our shipping policy and charges if any.

Notify Factory within 5 days ARO (Delivery): Red / no charge

Notify Factory 5 to 30 days ARO: Regular / no charge

Notify Factory 31 days ARO: Your cost for parts and shipping.

Please note we are only able to ship out from our location if notified by 12:00 PM CST. Calls received after this time will ship the following business day.

International shipping will need to be discussed prior to shipping.

Call us M-F 7:30 am to 5 pm 608-326-8406



PHONE: (608) 326-8406
FAX: (608) 326-4233
EMAIL: sales@dhsatellite.com

Please make notes below to help in future years with replacement needs.

Size of antenna: _____ Date: _____
Feedhorn make: _____ Model: _____
LNB Make: _____ Model: _____